

Ben Ø=160/180, Bom Ø=120/140

Ben - bom samles efter
montageprincip 1. Topmontage

Fundament og afmærkning montageprincip 19.

Betonforbrug: 2 sække tørbeton / hul

Fri faldhøjde: 1,35 m

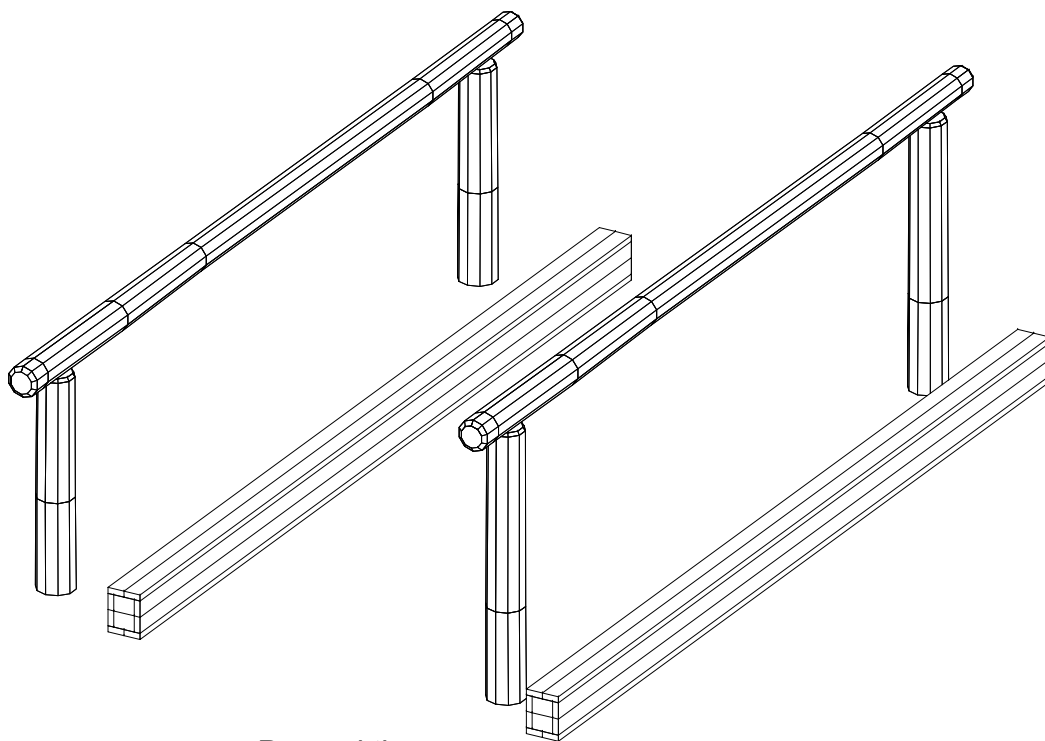
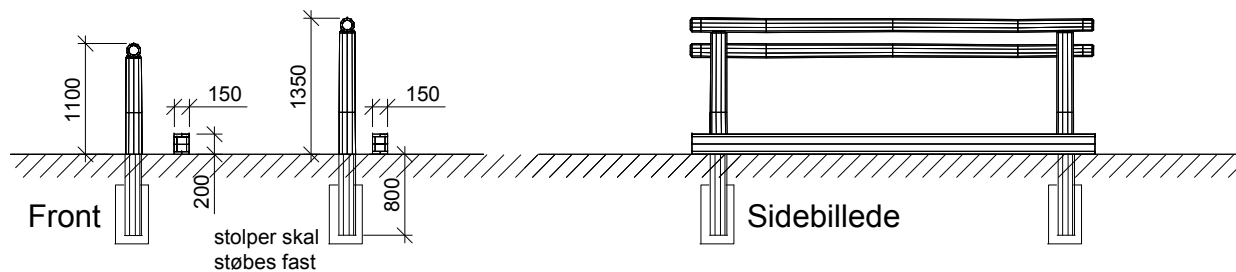

Perspektiv

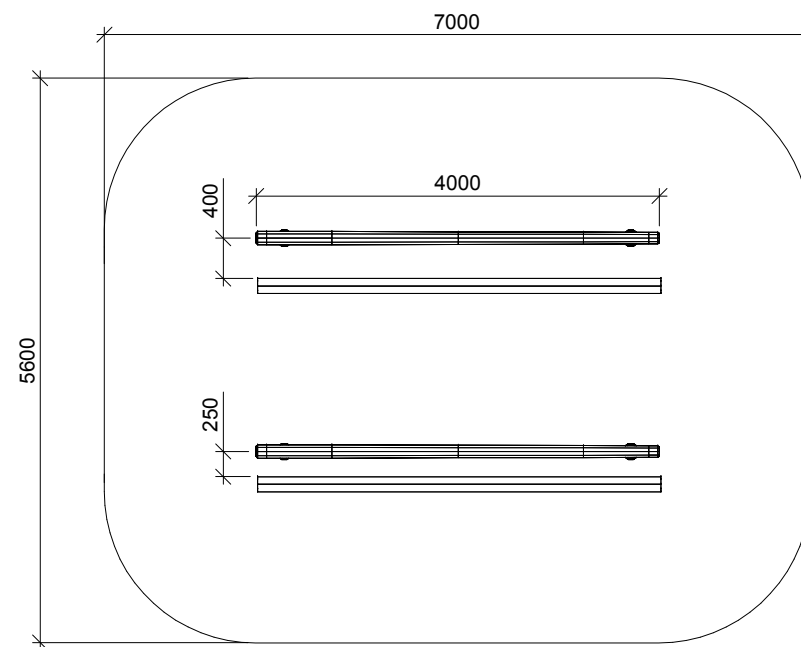

Plan