

Ben $\varnothing=160/180$, Bom $\varnothing=160/180$

Ben - bom samles efter
montageprincip 1. Topmontage

Fundament og afmærkning montageprincip 19.

Betonforbrug: 1 sæk tørbeton / hul

Fri faldhøjde: 0.99 m

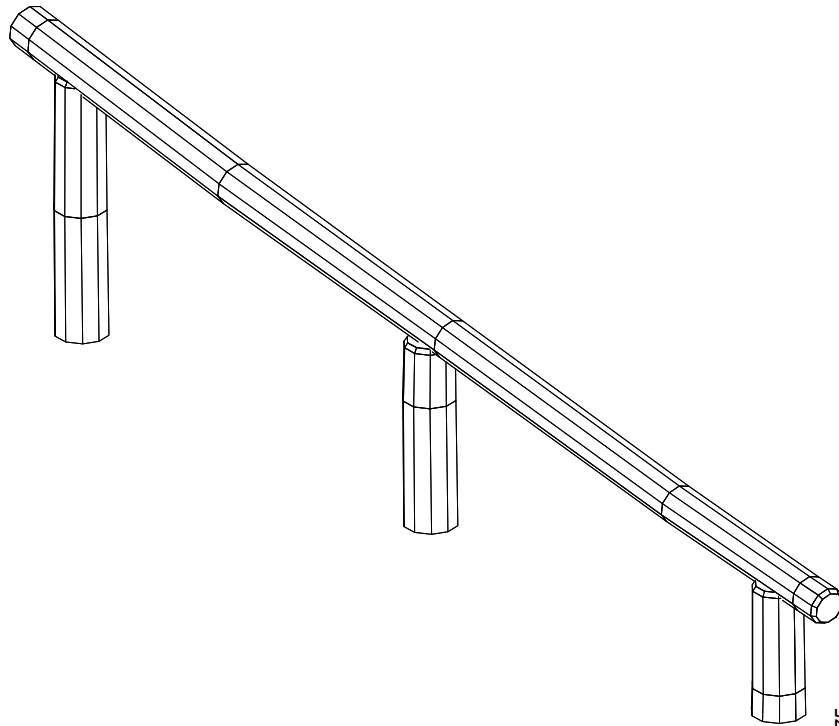

Perspektiv

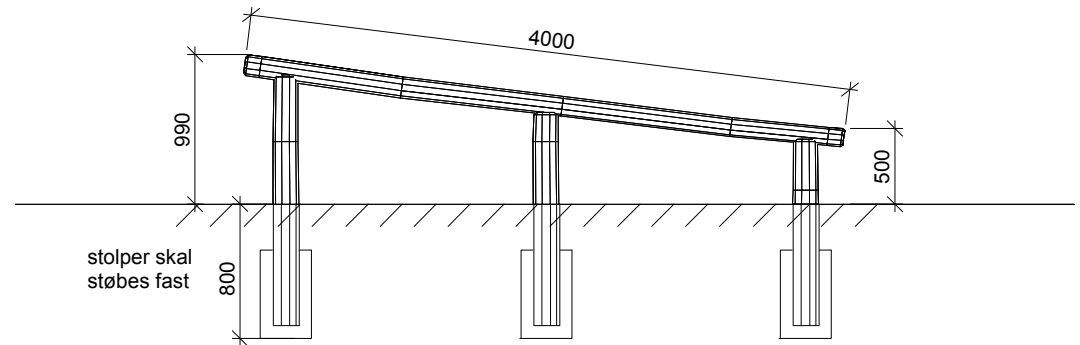

Sidebillede

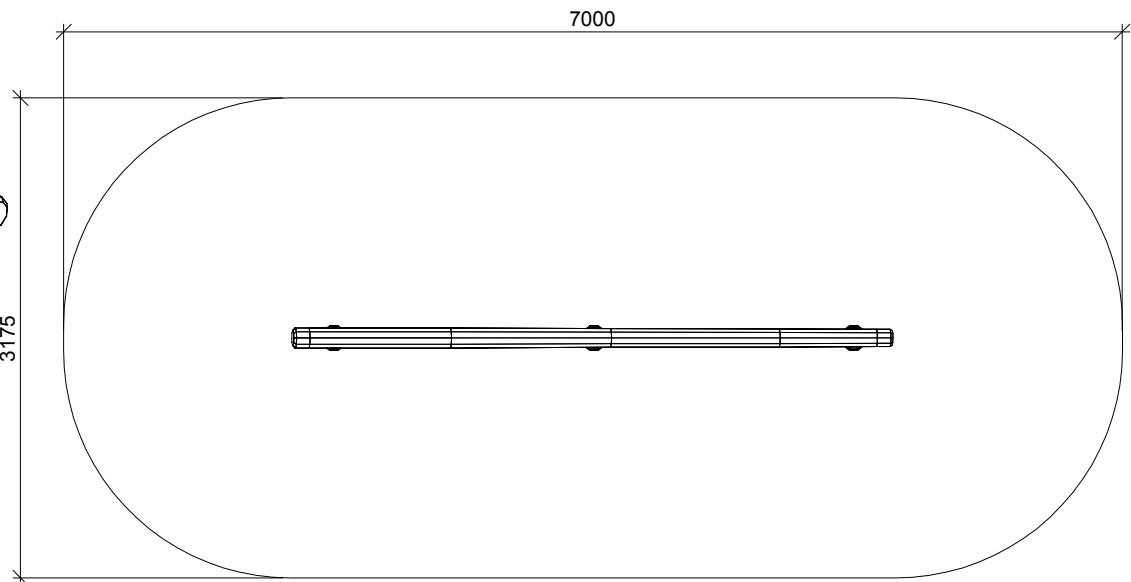

Plan