

Ben $\varnothing=160/180$

Fundament og afmærkning montageprincip 19.

Betonforbrug: 1 sæk tørbeton / hul

Fri faldhøjde: 1,45 m

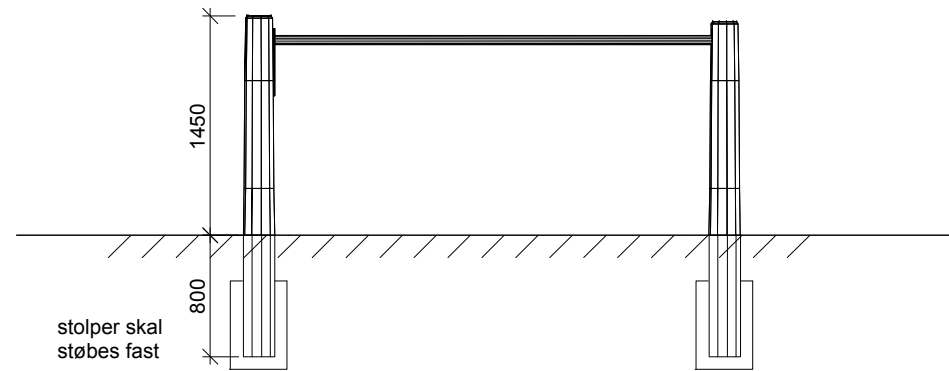

Sidebillede

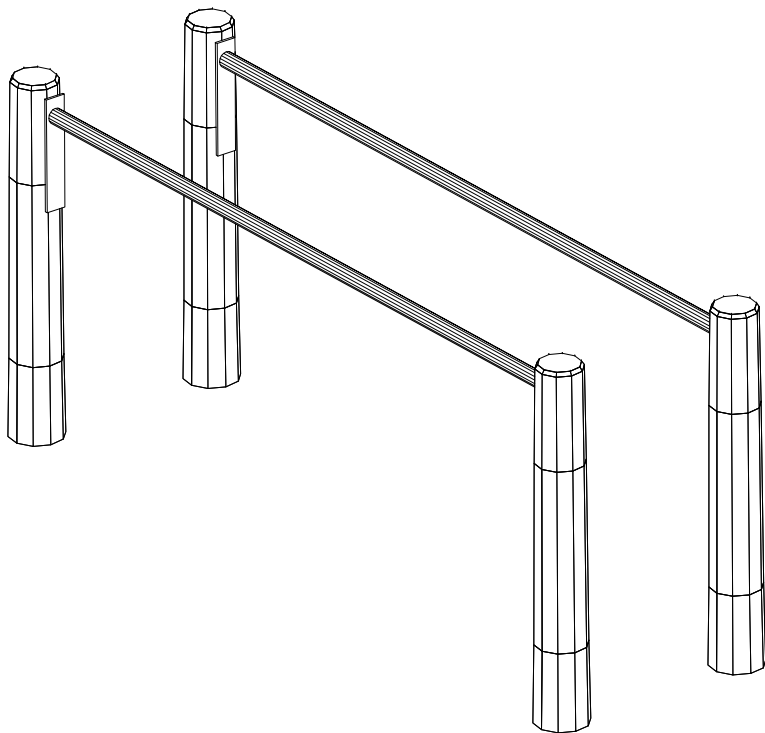

Perspektiv

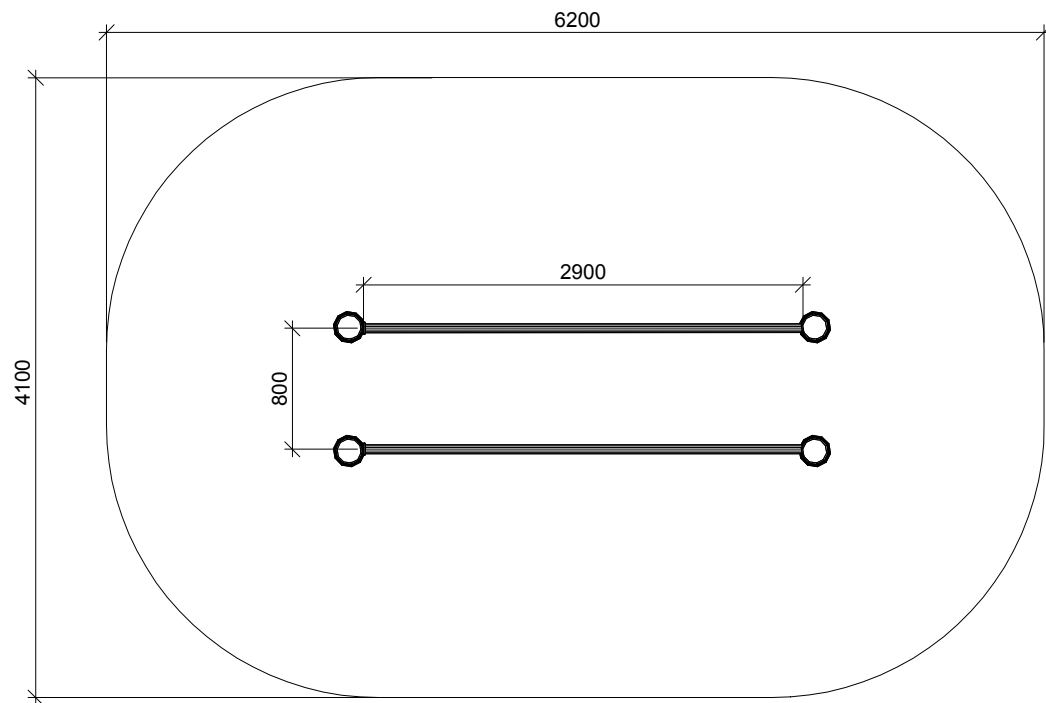

Plan