

Tunnel		
Sag. nr. LE 20545	HOVEDTEGNING	mnl : 1:20

DATO	29-09-2010
REV.	25.02.2011
	15.06.2011

Sider:
27 mm Kalmar

Ramme og bund:
45x95 bjælker lærk.

Gulv:
27x118 terrassebæt.

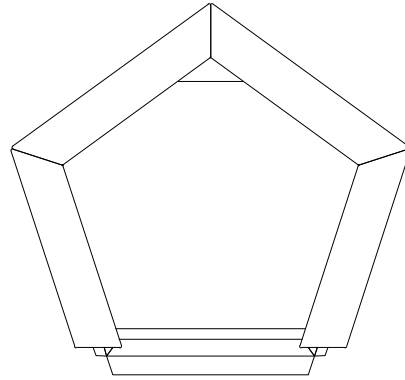

Front

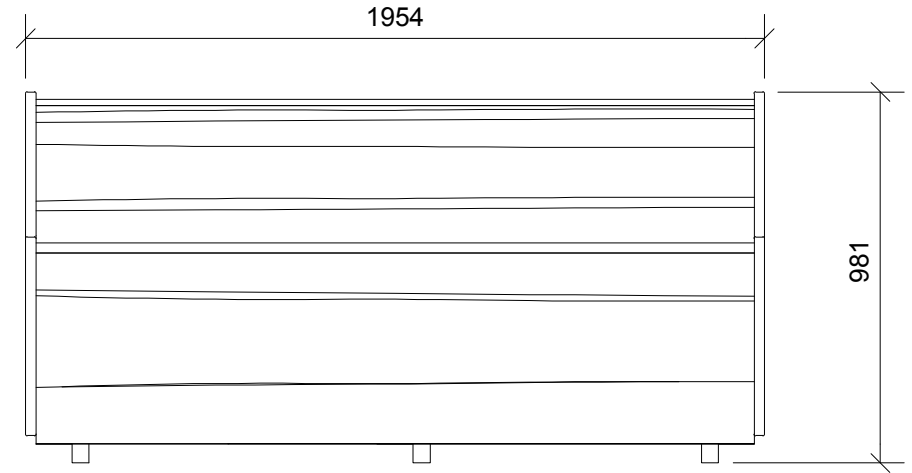

Side

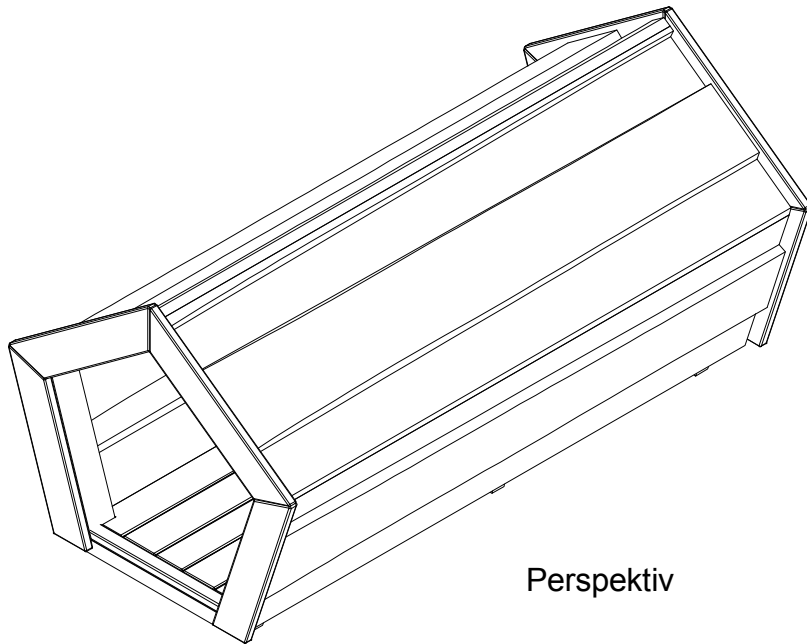

Perspektiv

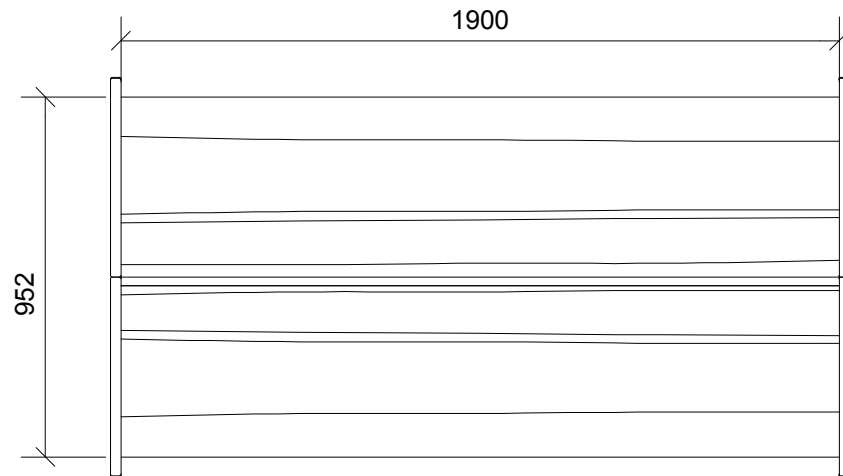

Plan